

PAPER NAME

DSMV Modelling

AUTHOR

Talitha Syahla Janiar Arifin

WORD COUNT

3922 Words

CHARACTER COUNT

21511 Characters

PAGE COUNT

6 Pages

FILE SIZE

315.8KB

SUBMISSION DATE

Feb 10, 2023 7:31?AM GMT+7

REPORT DATE

Feb 10, 2023 7:32?AM GMT+7

● 18% Overall Similarity

The combined total of all matches, including overlapping sources, for each database.

- 18% Internet database
- 0% Publications database
- Crossref Posted Content database
- 1% Submitted Works database

● Excluded from Similarity Report

- Crossref database
- Cited material
- Small Matches (Less than 8 words)
- Manually excluded sources

DSM-V Modelling as an Expert System Pilot in Classification of Insomnia Tendency Based on Time Range

Talitha Syahla Janiar Arifin¹, Wahyuningdiah Trisari Harsanti Putri², Tia Rahmania³

^{1,2}Department of Informatics, Universitas Paramadina Jakarta, Indonesia

³Department of Psychology, Universitas Paramadina Jakarta, Indonesia

¹talitha.arifin@students.paramadina.ac.id (*)

^{2,3}[wahyuningdiah.trisari, tia.rahmania]@paramadina.ac.id

Received: 2022-05-25; Accepted: 2022-07-26; Published: 2022-07-31

Abstract 6 Insomnia is a form of sleep disorder. This study develops an expert system model that can help determine the tendency of insomnia based on the Diagnostic and Statistical Manual for Mental Disorders (DSM-V) guidelines. The forward chaining design method was used in this study because it is bottom-up by collecting facts from patients and concluded based on the DSM-V guidelines. The forward chaining method was chosen to test the hypothesis of the classification of insomnia tendencies. The factual information then acts as a knowledge base fed into computer programs that can generate system rules. In addition, tacit knowledge 2 is used, as evidenced by O'Leary validation, to strengthen the validation of psychologist practitioners. There are three validation criteria: the accuracy of the knowledge base, completeness of the knowledge base, and condition-decision matches. The parameters used are based on complaints, dysfunction, time range, and other factors. The results of modeling and analysis of the rule system using the forward chaining method classify insomnia tendencies into three types based on time range: episodic, persistent, and recurring. The validation results carried out by practicing psychologists based on the analysis showed that the three rule systems were following the DSM-V guidelines and practical experience.

Keywords— Sleep Disorder, Insomnia, DSM-V, Artificial Intelligence, Expert System, O'leary Validation, Forward Chaining.

I. INTRODUCTION

Insomnia is a form of sleep disorder. The percentage of insomnias in Indonesia is 10% of the total population of Indonesia, which is 238 million, or it can be said that there are around 23 million insomnias in Indonesia [1]. Among 23 million people with insomnia, in the adult category, 20% to 50% of people experience sleep disorders, and about 17% have serious sleep disorders [2].

35 Insomnia is a sleep disorder with symptoms such as difficulty falling asleep for a certain time or waking habits. The impact of this insomnia can inhibit activity and damage organs - organs of the body. This is because sleep is a state where the body is rested from all forms of activity. When people sleep, the work of the brain becomes passive and does not respond to the outside world [3].

Several papers from previous research have created an expert system for diagnosing sleep disorders, including insomnia. The paper [4] uses an expert system for diagnosing sleep disorders with the Certainty Factor method to analyze the types of sleep disorders and find solutions. The researchers [5] use an expert system to diagnose nine types of sleep disorders, one of which is insomnia, which is focused on people aged 50 years and over using the forward chaining method, where the purpose of this study is to replace doctors in diagnosing diseases. The paper [6] uses an expert system for diagnosing four types of sleep disorders, one of which is insomnia, with the Dempster Shafer method. The research [7] uses an expert system with the Naive Bayes algorithm method in diagnosing non-organic sleep disorders, one of which was insomnia, by referring to the PPDGJ III guidelines.

However, in the previous reference paper, the study was conducted to diagnose sleep disorders in general and not specifically to diagnose insomnia.

This study uses the forward chaining method adopted in previous research, namely the results of research [8] using the Forward and Backward Chaining method for hydroponic vegetable cultivation, and the study [9] uses the Naive Bayes expert system method for the detection of digestive diseases

Therefore, this paper develops an expert system model to help determine insomnia tendencies based on the DSM-V guidelines currently used by psychology practitioners. In this study, DSM-V was used as a knowledge base within the framework of an expert system and validation from psychology practitioners using the O'Leary 2 method. The O'Leary method refers to 3 criteria, including accuracy of the knowledge base, completeness of the knowledge base, and Condition-decision matches.

Insomnia parameters studied in this study were (1) complaints factors, (2) dysfunction factors, (3) time range factors, and (4) other factors.

II. RESEARCH METHODOLOGY

This study uses a model design method with qualitative data. The expert system used is the forward chaining type with concept modeling based on DSM-V. Concept modeling is done with workflow based on the flow in Figure 1.

Forward chaining is a strategy to find conclusions on a problem by collecting data or facts with forwarding search methods, where conclusions will be obtained from the premise rules following the information in the knowledge base [10]. The discussion in this paper uses the forward chaining method

because the diagnostic method for insomnia is bottom-up, namely collecting some facts from patients, concluding based on DSM-V guidelines and tacit knowledge from practitioners trained in diagnosing insomnia.

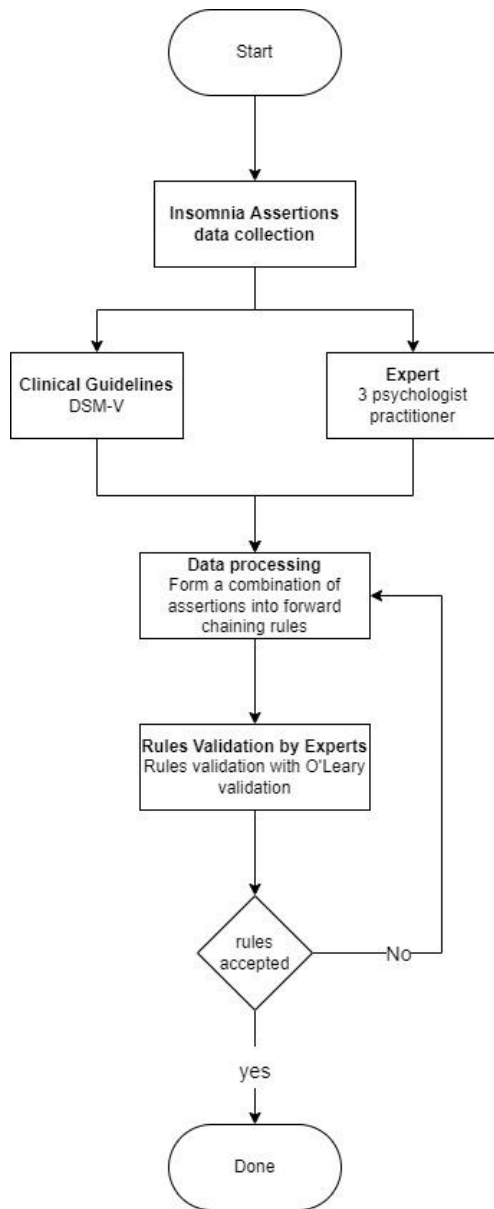

Figure 1. Research Workflow

A. Artificial Intelligence

'Intelligence' is the ability to understand and perform an activity, where the term can be said as a logical understanding that is studied and planned to solve a problem. 'Artificial' is a form that is not real or just a simulation. Artificial Intelligence (AI) is a simulation that can understand and perform an activity to solve a problem [11]. AI is one of the computer sciences in the form of intelligent machines that can simplify human work and even exceed human capabilities [12]. In another definition, AI is defined as a knowledge mechanism

carried out for research, application, and instruction on computer programming to be able to do something [13].

AI can perform analysis and decision-making more easily, quickly, and accurately as in the system that has been created [14]. In its application, AI uses symbols such as numbers, letters, and variables in an interrelated formula to solve a problem. Another feature is AI problem solving with programming algorithms, where this program can provide many possibilities according to the existing conditions [15].

The ultimate goal of AI is AGI (Artificial General Intelligence). But in its development, AGI is a very broad topic. AI is broken down into several sub-fields to achieve AGI, including robotics, computer vision, artificial neural system, natural language processing, speech recognition, and expert systems [16].

B. Expert System

According to Professor Edward Feigenbaum, an expert system is an intelligent computer program with knowledge and inference procedures in solving a problem that requires special expertise from an expert [17]. An expert has special knowledge or expertise usually not owned by others. In other words, an expert can solve a science that most people cannot solve. The basic concept of an expert system can be seen in Figure 2.

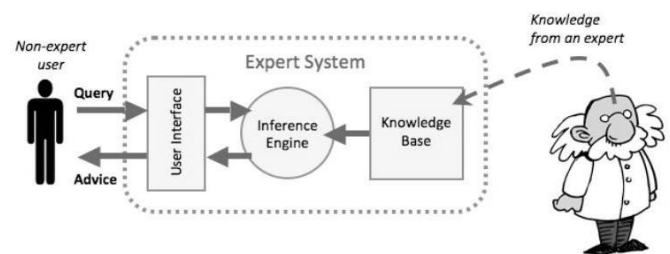

Figure 2. The Basic Concept Of Expert System From (Tan, 2007) [18]

As Figure 2 shows, the basic concept of an expert system can be illustrated when the user provides facts or information to the system. The system will then provide a response based on the expert opinion of the user. The system will be displayed on the user interface so that the user and the system can interact. In short, if represented in the system, then there are "IF" and "THEN" methods that represent every possibility that occurs to get a conclusion [19]. The expert system has three main components, as shown in Figure 2.

1) *Knowledge Base*: The knowledge base is a variety of knowledge obtained from several experts and researchers in their fields that can solve certain problems [20]. In this study, DSM-V is used as a knowledge base on the expert system created. The Diagnostic and Statistical Manual (DSM) of Mental Disorders is a book that the American Psychiatric Association has recognized as a standard since 1952. This book is used as a guide by medical professionals, researchers, psychiatric drug regulatory agencies, health insurance companies, pharmaceutical companies, legal systems, and

alternative health policymakers. It was first published in 1952, and the Diagnostic and Statistical Manual of Mental Diseases (DSM) provides a classification of mental disorders and a set of standard criteria [21]. In addition to the DSM-V guidelines, the results of interviews with practicing psychologists were used for further interpretation and validation of the DSM-V guidelines.

2) *Inference Engine*: The inference engine contains a series to determine conclusions using a reasoning system with information knowledge and working memory. This machine inference is obtained from the fact-matching process from the state statement stated in the premise [22]. In this study, the inference engine is the model built. There are two main techniques in developing an inference engine model: Forward chaining and Backward Chaining. Forward chaining is a search technique or forward search with a pre-existing knowledge base that can be used as a solution that produces conclusions based on facts [23]. The search using the forward chaining method starts with data, producing an IF rule that leads to a conclusion (THEN). Rules are generated from the flow of reasoning from the data to produce goals, and then goals produce facts, and the conclusion will be the final destination [24]. This study uses the forward chaining method to test the facts hypothesis on the diagnosis of insomnia. The result of the method used presents a special condition of insomnia.

3) *User Interface*: A user interface is a visual display created on an application to display an inference engine derived from a knowledge base. However, this study created no user interface because it only designed the expert system model.

C. Insomnia

According to the DSM-V book, insomnia is a type of sleep disorder with complaints related to dissatisfaction with the quantity and quality of sleep [25]. Meanwhile, according to Kaplan and Sadock [26] According to Kaplan and Sadock, insomnia is a condition in which a person has complaints of difficulty entering sleep, difficulty maintaining sleep, or not getting enough sleep. According to Tyrer [27], Insomnia is the result of a habit of staying up late for several nights that never seem to end [28].

According to Ruth, it is estimated that 10-15% of insomniacs are adults. It is estimated that 10% - 15% of the adult population experience sleep disturbances during the day, and another 6% - 10% have insomnia symptoms [29]. There are several general criteria for the diagnosis of insomnia, namely as follows [30]:

- Sleep complaints related to dissatisfaction with the quantity or quality of sleep with symptoms, namely difficulty initiating sleep, difficulty maintaining sleep, and waking up early in the morning and then unable to go back to sleep. This happens despite having the opportunity to sleep.
- Significant life disturbances include work, education, behavior, and others.
- Trouble sleeping occurs at least three nights per week.

- Trouble sleeping suffered for three months.
- Trouble sleeping occurs despite adequate opportunity to sleep.
- Have narcolepsy, sleep-related breathing disorder, circadian rhythm sleep-wake disorder, and parasomnias, which cannot be confirmed as a direct factor in insomnia.
- Not under the physiology of a substance such as drug abuse or treatment for a mental disorder or other medical condition.
- Certain psychological illnesses and physical ailments also need medical attention (but not always a factor in insomnia).

There are three classifications of insomnia based on the time the patient experienced symptoms:

1) *Episodic*: A type of insomnia whose symptoms last for at least one month but are less than three months that have an impact on sleep schedules and are influenced by an uncomfortable sleep environment.

2) *Persistent*: A type of insomnia whose symptoms last three months or more. Patients with persistent insomnia have a maladaptive sleep habits (e.g., spending excessive time in bed, adhering to erratic sleep schedules and naps) and cognitions (fear of sleeplessness, worry about daytime disturbances, and monitoring hours) during the onset of the sleep difficulty.

3) *Recurrent*: A type of insomnia in which symptoms last two months or more episodes within one year.

III. RESULT AND DISCUSSION

Based on the DSM-V clinical guidelines, the tendency of insomnia is influenced by four factors, namely complaints, dysfunction, duration of time, and other factors such as flow in Figure 3.

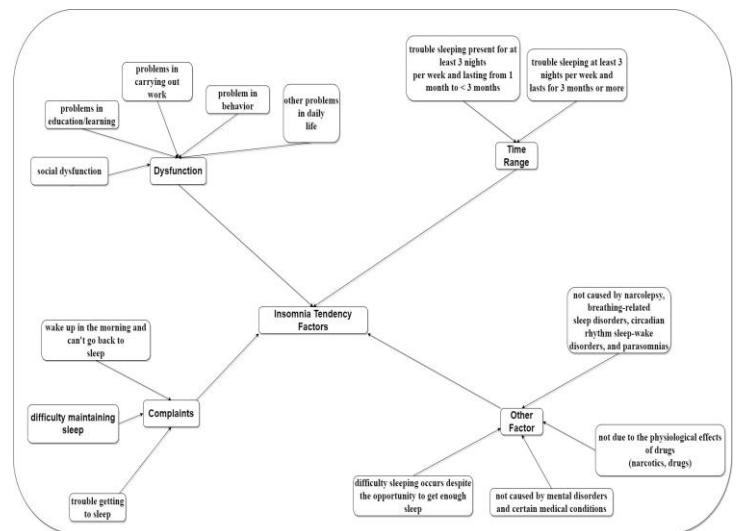

Figure 3. Insomnia Tendency Factors

The fact information will then be entered into a computer program so that the information acts as a knowledge base that can classify insomnia tendencies. Information data on the

classification of 3 types of insomnia based on time range can be seen in Table I.

TABLE I
 CLASSIFICATION OF INSOMNIA BY TIME RANGE

Code	Insomnia Type	Description
I1	episodic	This type of insomnia occurs due to a combination of various supporting factors, namely Complaints (CF), Dysfunction (DF), and Other Factors (OF), and with a Time Range (TR) of 1 month to < 3 months.
I2	persistent	This type of insomnia occurs due to a combination of various supporting factors, namely Complaints (CF), Dysfunction (DF), and Other Factors (OF) and with a Time Range (TR) of 3 months or more.
I3	recurrent	This type of insomnia occurs due to a combination of various supporting factors, namely Complaints (CF), Dysfunction (DF), Other Factors (OF), and with a Time Range (TR) of 2 episodes in 1 year.

The three types can be characterized by four factors in Tables II to V.

TABLE II
 COMPLAINTS FACTOR (CF)

Code	Description
CF1	trouble getting to sleep
CF2	difficulty maintaining sleep
CF3	wake up in the morning and can't go back to sleep

TABLE III
 DYSFUNCTION FACTOR (DF)

Code	Description
DF1	social dysfunction
DF2	problems in education/learning
DF3	problems in carrying out work
DF4	problem in behavior
DF5	other problems in daily life

TABLE IV
 TIME RANGE FACTOR (TR)

Code	Description
TR1	trouble sleeping present for at least three nights per week and lasting from 1 month to < 3 months
TR2	trouble sleeping at least three nights per week and lasts for three months or more

TABLE V
 OTHER FACTOR (OF)

Code	Description
OF1	not caused by narcolepsy, breathing-related sleep disorders, circadian rhythm sleep-wake disorders, and parasomnias
OF2	not due to the physiological effects of drugs (narcotics, drugs)
OF3	not caused by mental disorders and certain medical conditions
OF4	difficulty sleeping occurs despite the opportunity to get enough sleep

From the data obtained in Tables I to V, expert system rules can be formed using the forward chaining method, where rules 1, 2, and 3 are shown in Figures 4, 5, and 6.

a) Rule 1: There is a combination of Complaints (CF), Dysfunction (DF), and Other Factors (OF) and with a Time

Range (TR) of 1 month to < 3 months. From these rules, it can be concluded that patients can be categorized as episodic insomnia if they experience a combination of the above-mentioned insomnia tendencies.

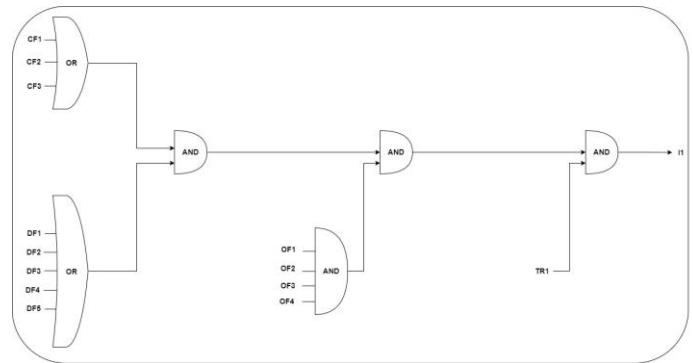

Figure 4. Rule 1: Episodic Insomnia Tendency

b) Rule 2: There is a combination of Complaints (CF), Dysfunction (DF), and Other Factors (OF) and with a Time Range (TR) of 3 months or more. From these rules, it can be concluded that patients can be categorized as persistent insomnia if they experience a combination of the above-mentioned insomnia tendencies.

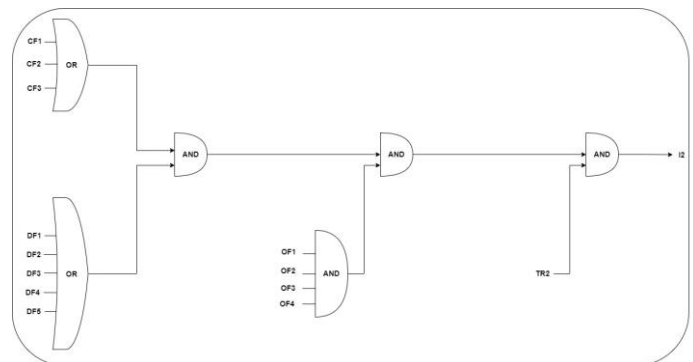

Figure 5. Rule 2: Persistent Insomnia Tendency

c) Rule 3: There is a combination of Complaints (CF), Dysfunction (DF), and Other Factors (OF) and with a Time Range (TR) of 2 episodes in 1 year. From these rules, it can be concluded that patients can be categorized as recurrent insomnia if they experience a combination of the above-mentioned insomnia tendencies.

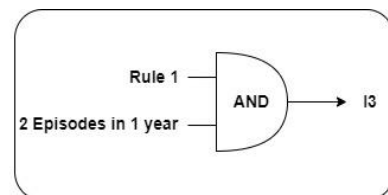

Figure 6. Rule 3: Recurrent Insomnia Tendency

D. Validation

The validation process is carried out by experts against the rules that have been made. Validation using the O'Leary

method is specifically used for expert systems. There are three validation criteria used, which can be seen in Table VI.

TABLE VI
 O'LEARY VALIDATION CRITERIA [31]

Code	Criteria	Explanation
VF1	Accuracy of the knowledge base	Check the accuracy of the rules that have been created with the knowledge base
VF2	Completeness of the knowledge base	Check the completeness of the rules and orders
VF3	Condition-decision matches	Equation of decisions and conditions contained in the system with experts judgment.

Validation was carried out by three psychologists, including one psychologist who had a license to practice as a practicing psychologist for 18 years and two psychologists who had a license to practice as a psychologist for two years.

The validation process is carried out by combining factual information contained in the rules. Where in this case, the binary number is used, namely 0 for facts that are not mandatory for insomnia patients and 1 for facts that insomnia patients must own. So, from the data obtained validation results in Table VII.

TABLE VII
 O'LEARY'S VALIDATION RESULT

Code	Criteria	Validation Result
VF1	Accuracy of the knowledge base	Three experts assessed the knowledge bases generated in Tables I to V according to DSM-V and psychologists' expert judgment.
VF2	Completeness of the knowledge base	The classification of insomnia tendencies for the time range generated in Rules 1, 2, and 3 based on the DSM-V knowledge base was complete with the presenting symptoms and characteristics.
VF3	Condition-decision matches	According to the three experts, the antecedent of the rule (IF clause) and its consequent (THEN clause) is appropriate.

IV. CONCLUSION

Based on the author's analysis to answer the purpose of writing described in the introduction, the writer can then draw conclusions from the analysis that has been done. To classify the tendency of insomnia based on complaints, dysfunction, time range, and other factors, the author uses an expert system to form a system of rules based on the DSM-V clinical guidelines. The author successfully made modeling and expert systems that can classify the tendency of insomnia.

The findings, which were gathered through the course of this research, provide a model for the inference engine in the form of three rules that have been outlined. The results of the psychologist's validation stated that the three rules were

appropriate for classifying episodic, persistent, and recurrent insomnia tendencies.

REFERENCE

- [1] N. Olii, B. J. Kepel, and W. Silolonga, "Hubungan Kejadian Insomnia Dengan Konsentrasi Belajar Pada Mahasiswa Semester V Program Studi Ilmu Keperawatan Fakultas Kedokteran Universitas Sam Ratulangi," *e-journal Keperawatan (e-Kp)*, vol. 6, no. 1, pp. 1–7, 2018.
- [2] F. Mading, "Gambaran karakteristik lanjut usia yang mengalami insomnia di Panti Wreda Dharma Bakti Pajang Surakarta," Universitas Muhammadiyah Surakarta, 2015.
- [3] B. W. Atmadja, "Fisiologi Tidur," *J. Kedokt. Maranatha*, vol. 1, no. 2, pp. 36–39, 2010.
- [4] A. H. Amalia, "Sistem Pakar Pembantu Diagnosa Penyakit Gangguan Tidur Dengan Metode Certainty Factor," Universitas Muhammadiyah Ponorogo, 2021.
- [5] R. Noviana, Winarti, and D. Indriani, "Aplikasi Sistem Pakar Untuk Mendiagnosa Penyakit Gangguan Tidur Dengan Turbo Prolog 2.0," *Seminar Nasional Teknologi Informasi dan Multimedia 2013*, 2013.
- [6] I. D. Ananda, R. Kurniawan, N. Yanti, and F. Insani, "Sistem Pakar untuk Mendiagnosis Gangguan Tidur Menggunakan Metode Dempster Shafer," *JIMP J. Inform. Merdeka Pasuruan*, vol. 6, no. 3, pp. 1–8, 2021.
- [7] I. A. Prabowo, D. Remawati, and A. P. Wardana, "Klasifikasi Tingkat Gangguan Tidur Menggunakan Algoritma Naive Bayes," *J. Teknol. Inf. dan Komun.*, vol. 8, no. 2, pp. 40–48, 2020.
- [8] H. T. Sakti and A. Thoriq, "Expert System for Hydroponic Vegetable Cultivation Using Forward and Backward Chaining Inference Technique," *Inf. J. Ilm. Bid. Teknol. Inf. dan Komun.*, vol. 6, no. 2, pp. 69–74, 2021.
- [9] D. S. Salsabila and R. Tanamal, "Design of Expert System for Digestive Diseases Identification Using Naive Bayes Methodology for iOS-Based Application," *Inf. J. Ilm. Bid. Teknol. Inf. dan Komun.*, vol. 5, no. 2, p. 92, 2020.
- [10] B. A. Dewantara, "Sistem Pakar Pembantu Diagnosa Jenis Gangguan Tidur dengan Metode Forward Chaining Berbasis PHP dan SQL," Universitas Negeri Semarang, 2015.
- [11] Y. Budiharto, *AI for Beginner*. BINUS (Bina Nusantara) University.
- [12] A. Al-Ajlan, "The Comparison between Forward and Backward Chaining," *Int. J. Mach. Learn. Comput.*, vol. 5, no. 2, pp. 106–113, 2015.
- [13] S. Andika, "Pembangunan Aplikasi Sistem Pakar Gangguan Perkembangan Perwasif Dengan Metode Dempster Shafer Berbasis Web," Universitas Atma Jaya Yogyakarta, 2015.
- [14] G. Orlan, I. Made Suandi Putra MSc, CIA, C. Yullyan, SE, MAK, Ak., CPA, CIA, "PERSPEKTIF DAN PANDANGAN GLOBAL Kecerdasan Buatan (Artificial Intelligence/AI) -Pertimbangan untuk Pensi Audit Internal," *Artif. Intell.*, vol. 9, no. 2, pp. 1–9, 2017.
- [15] K. K. Lee and K. Joshi, "Understanding the Role of Cultural Context and User Interaction in Artificial Intelligence Based Systems," *Glob. Inf. Technol. Manag.*, vol. 23, no. 3, pp. 1–5, 2020.
- [16] F. Rohman and A. Fauziah, "Rancang Bangun Aplikasi Sistem Pakar Untuk Menentukan Jenis Gangguan Perkembangan Pada Anak," *Media Inform.*, vol. 6, no. 1, pp. 1–23, 2008.
- [17] A. Triyanto, "Sistem Pakar Diagnosa Penyakit Infeksi Virus Pada Anak Menggunakan Metode Forward Chaining," Sekolah Tinggi Manajemen Informatika Dan Komputer, 2015.
- [18] F. Tan, L. Wahidin, S. N. Khalil, and N. Tamaldin, "The application of expert system: A review of research and applications," *RPN J. Eng. Appl. Sci.*, vol. 11, no. 4, pp. 2448–2453, 2016.
- [19] M. Garratano, J. C. G. D., and Riley, *Expert systems principles and programming*. Thomson Course Technology, 2005.
- [20] C. Rosnelly, *Sistem Pakar Konsep dan Teori*. Yogyakarta: CV ANDI EFFSET (Penerbit ANDI), 2012.
- [21] S. Prastianingrum and A. S. Purnomo, "Sistem Pakar Diagnosa Fobia Menggunakan Metode Certainty Factor," *JMAI (Jurnal Multimed. Artif. Intell.*, vol. 3, no. 2, pp. 73–80, 2019.
- [22] B. Wijaya and R. Tanamal, "Rancang Bangun Aplikasi Sistem Pakar Berbasis Android Menggunakan Metode Forward Chaining Untuk Mendiagnosis Kerusakan Pada Hardware Laptop," *TEKNIKA*, vol. 8, no. 1, pp. 25–35, 2019.

● **18% Overall Similarity**

Top sources found in the following databases:

- 18% Internet database
- 0% Publications database
- Crossref Posted Content database
- 1% Submitted Works database

TOP SOURCES

The sources with the highest number of matches within the submission. Overlapping sources will not be displayed.

1	ejournal.uin-suka.ac.id Internet	1%
2	utpedia.utp.edu.my Internet	1%
3	sistemasi.ftik.unisi.ac.id Internet	1%
4	elibrary.nusamandiri.ac.id Internet	<1%
5	e-journal.hamzanwadi.ac.id Internet	<1%
6	ema.europa.eu Internet	<1%
7	jurnal.stikesimcbintaro.ac.id Internet	<1%
8	repositor.umm.ac.id Internet	<1%
9	repository.urecol.org Internet	<1%

10	jurnal.unimed.ac.id Internet	<1%
11	lib.unnes.ac.id Internet	<1%
12	drquit.info Internet	<1%
13	id.scribd.com Internet	<1%
14	e-dokumen.com Internet	<1%
15	Universitas Paramadina on 2021-01-18 Submitted works	<1%
16	ejournal.poltektegal.ac.id Internet	<1%
17	publikasi.mercubuana.ac.id Internet	<1%
18	vdoc.pub Internet	<1%
19	archive.org Internet	<1%
20	downloads.hindawi.com Internet	<1%
21	works.bepress.com Internet	<1%

22	neliti.com	Internet	<1%
23	freepatentsonline.com	Internet	<1%
24	dokumen.pub	Internet	<1%
25	ijphs.iaescore.com	Internet	<1%
26	ijstm.inarah.co.id	Internet	<1%
27	scribd.com	Internet	<1%
28	jurnal.untan.ac.id	Internet	<1%
29	ijair.id	Internet	<1%
30	catalog.uttyler.edu	Internet	<1%
31	link.umsl.edu	Internet	<1%
32	myassignmenthelp.com	Internet	<1%
33	jurnal.una.ac.id	Internet	<1%

34	centerforautismresearch.com	<1%
	Internet	
35	clinicaltrials.gov	<1%
	Internet	
36	publishing-widyagama.ac.id	<1%
	Internet	
37	site.unibo.it	<1%
	Internet	

● Excluded from Similarity Report

- Crossref database
- Small Matches (Less than 8 words)
- Cited material
- Manually excluded sources

EXCLUDED SOURCES

ejournal.unitomo.ac.id	78%
Internet	
researchgate.net	10%
Internet	
repository.ubaya.ac.id	7%
Internet	
semanticscholar.org	4%
Internet	
pdfs.semanticscholar.org	3%
Internet	
eprints.umpo.ac.id	2%
Internet	
garuda.kemdikbud.go.id	2%
Internet	